

RST-DE Series Datasheet

- 21 mm total height
- 0.02° repeatability
- 4 mm aperture
- 50 N load capacity
- Worm gear driven for continuous rotation
- Built-in controller; daisy-chains with other Zaber products

Zaber's RST-DE Series products are motorized rotation stages with built-in direct reading encoders for high accuracy motion. Rated for a 50 kg centered load capacity and 10 N-m of torque, they are ideal for high load, angular positioning applications. RST-DE stages are designed for plug-and-play use with any of Zaber's controllers.

Drawings

ZABER

X-RSM Motorized Rotary Stage With Built In Controller
dimensions in mm

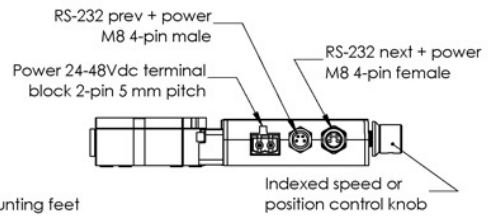
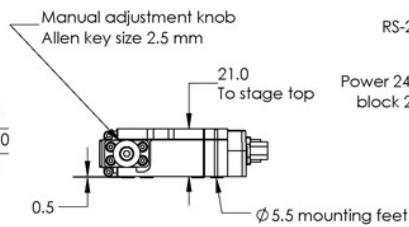
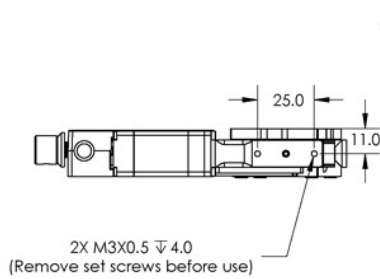
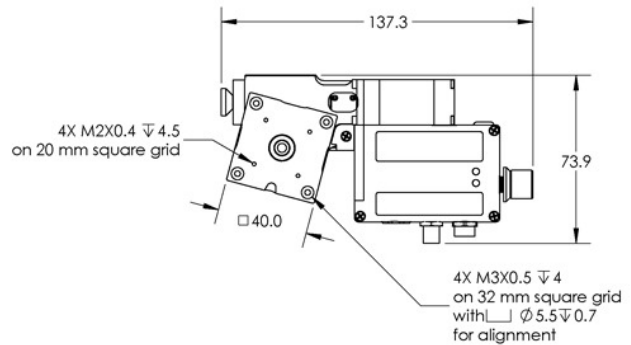
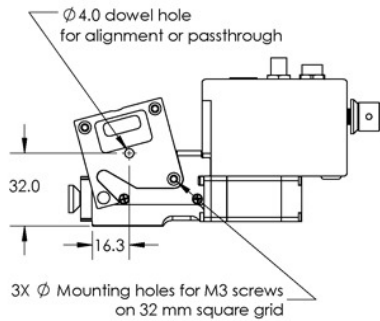
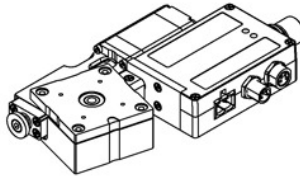

DWG 1106 #02

Specifications

Specification	Value	Alternate Unit
Microstep Size (Default Resolution)	0.00046875 °	8.181 μrad
Built-in Controller	Yes	
Range	360 °	
Accuracy (unidirectional)	0.14 °	2.443000 mrad
Repeatability	< 0.02 °	< 0.349 mrad
Backlash	< 0.04 °	< 0.698 mrad
Maximum Speed	120 °/s	20.0 rpm
Minimum Speed	0.000286 °/s	4.992 μrad/s
Encoder Type	None	
Communication Interface	RS-232	
Communication Protocol	Zaber ASCII (Default), Zaber Binary	
Maximum Continuous Torque	60 N-cm	85.0 oz-in
Maximum Centered Load	50 N	11.2 lb
Maximum Cantilever Load	100 N-cm	141.6 oz-in
Stage Top Dimension	40 mm	1.575 "
Maximum Current Draw	350 mA	
Power Supply	24-48 VDC	
Power Plug	2-pin Screw Terminal	
Angular Motion Per Motor Rev	6 °	
Motor Steps Per Rev	200	
Motor Type	Stepper (2 phase)	
Inductance	3.5 mH/phase	
Default Resolution	1/64 of a step	
Data Cable Connection	Locking 4-pin M8	
Motor Frame Size	NEMA 08	
Mechanical Drive System	Precision Worm Gear	
Limit or Home Sensing	Magnetic home sensor	
Manual Control	Yes	
Mounting Interface	M2 and M3 mounting holes	
Vacuum Compatible	No	

Specification	Value	Alternate Unit
Operating Temperature Range	0-50 °C	
RoHS Compliant	Yes	
CE Compliant	Yes	
Weight	0.278 kg	0.613 lb

Charts

